

Performance Plus 8GU95-3vm Underfloor Heating

Want warm feet even when you go barefoot? The Performance Plus Underfloor Heat Pump System maintains a constant floor surface temperature of 22-26° C by way of natural radiation and convection.

With traditional forms of heating, temperature variations and draughts can occur. With a Performance Plus Underfloor Heat Pump System this does not happen as the pipe work distributes heat to the entire floor area, so there are no hot or cold spots. Separate controls for each zone means you can tailor the water flow for each area to suit individual room or zone requirements night and day. 'U' series Performance Plus Heat pump water heaters have been developed specifically for use in residential and commercial hydronic floor heating systems.

100% New Zealand owned and operated, Hot Water Heat Pumps Ltd Performance Plus range is the largest in Australasia, manufacturing over 28 standard models for underfloor heating alone, plus custom models on request. This means whether you require 5kW or 95kW or larger; Hot Water Heat Pumps Ltd has a solution to meet your requirements. Custom models such as the DuoHeat range can also heat other applications like domestic hot water, adding further value and reducing running costs in another high energy usage area.



P UNDERFLOOR HEAT PUMP FEATURES

- Constant natural warmth from head to toe
- No dusty air particles or toxic gas fumes
- High efficiency hermetically sealed compressor
- Ozone friendly refrigerants
- Epoxy coated corrosion resistant coil fins
- Thermostatically controlled temperatures
- Designed for optimal performance even in freezing conditions
- Built for life

OPTIONAL EQUIPMENT

- Remote box for the control system
- Ducts and grills for plant room installs
- Rubber anti-vibration pads

IDEAL APPLICATIONS

- Underfloor heating
- Low temperature hot water

Experience the best in heat pump
water heater technology

P PERFORMANCE
+ PLUS

HOT WATER HEAT PUMPS LTD

Advancing Water Heat Pump Technology SINCE 1980

Performance Plus 8GU95-3vm

Technical Specifications

Heating - kW output *1	95
kW input	28.0
Power Supply	3 Phase + N & E
Circuit Breaker - 3 Pole D Curve	80 amps
Nominal compressor run amps	24.5 Per Phase (x2)
Fan full load amps	3.9 (x2)
Minimum flow rate - litre/second	2.8
Recommended flow rate - litre/second	5.65
Water connections	Application Specific
Dimensions LxWxH - mm	2508 x 1250 x 2490
Weight - kg	900
Air volume @ high speed litre/second	11,000
Sound pressure level, high dB(A) *2	66

NB: Designs and specifications are subject to change without notice.

*1 kW output values are nominal ratings based on 8°C wet bulb and 38°C water temperature.

*2 Sound pressure measured at 3m in decibels re 20 µPa.

Why buy from Hot Water Heat Pumps Ltd

Back up and service: You can be assured of unprecedented after-sales service. We provide free telephone and email support on all products, for the life of the product, even if you're outside of the warranty period. With periodic maintenance, your Hot Water Heat Pumps Ltd's product will provide you with a lifetime of efficient hot water heating.

Warranty: All of our commercial heat pump underfloor heater models carry a comprehensive two year parts and labour warranty, including the compressor, evaporator coils, heat exchanger and refrigeration systems. The titanium tube within the heat exchanger is covered against corrosion for 10 years.



Safety first: Our heat pump water heaters are fitted with protection systems to prevent damage in the event of a malfunction. Such as a flow switch to ensure the heat pump cannot operate without water flow and other refrigeration safeties. If a problem is identified, the unit automatically shuts down before damage can occur.

Energy efficient: Government agency EECA (Energy Efficiency Conservation Authority) has listed heat pumps as one of the most energy efficient forms of heating in New Zealand.

Clean and green: As heat pumps use renewable energy (air), they are safer and cleaner to run than fossil fuel burners and can lower CO₂ emissions by up to 70% (compared to gas and diesel burners).

INSTALLATION INSTRUCTIONS

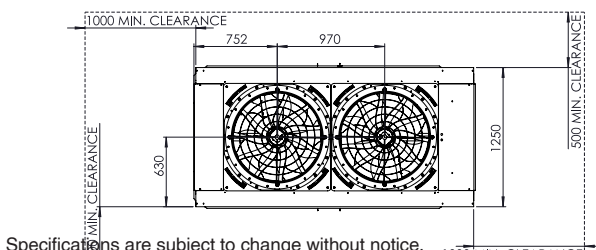

Specifications are subject to change without notice.

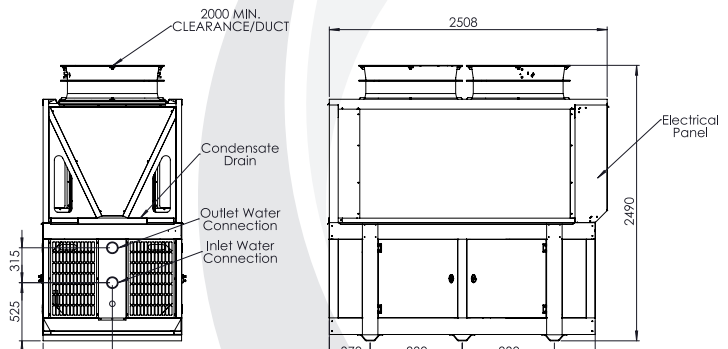

3 Corban Avenue, Henderson, Auckland 0612
 PO Box 21 586, Henderson, Auckland 0650
 Phone 09 838 9444 Fax 09 838 6223
 info@waterheating.co.nz

