



Titanium Series 8GP140-3H Swimming Pool or Spa Heater

The Titanium Series 8GP140-3H Swimming Pool or Spa Heater is part of our Performance Plus range of models. It ensures a constant pool or spa temperature every time. This unit is ideal for up to 438m²* size pools and spa pools.

Designed and engineered to perform all year round, even in New Zealand's harshest environments; the Titanium Series 8GP140-3H unit is made of heavy gauge galvanised steel cabinetry with a polyester powder coat finish which provides superior corrosion resistance. The evaporator coils' aluminium fins are epoxy coated giving extra protection in coastal areas where the air is salt-laden. The evaporator coils incorporate rifled copper tubes for better heat transfer.

All of our heat pump pool and spa heaters are fitted with proprietary titanium tube heat exchangers, with the titanium tubes providing superior resistance against corrosion. Due to its high energy efficiency, the Titanium Series 8GP140-3H Swimming Pool & Spa Heater has a extremely low cost of operation. Typically, for every 1kW of electric input, you receive 5kW worth of heat.



PERFORMANCE PLUS FEATURES

- Built in drain tray
- Water flow switch activated
- Titanium tube heat exchanger
- Ozone friendly refrigerants
- Epoxy coated corrosion resistant evaporator coils
- Built in refrigeration safety switches
- Electronic reverse cycle de-ice control
- Easy to operate electronic controller with digital display
- TX valve for more efficient low ambient operation
- Compressor has built in internal and external overload
- Optional WIFI or Modbus

*Refer to pool sizing chart

Experience the best in heat pump
water heater technology

PERFORMANCE PLUS BENEFITS

- Easy to install and operate
- Low operating costs and high efficiency
- Environmentally friendly
- Durable and long life expectancy
- Engineered and built in New Zealand
- Automatically maintains any set temperature in all weather

IDEAL APPLICATIONS

- Swimming pool
- Spa heating
- Hydroponics



Advancing Water Heat Pump Technology SINCE 1980

Titanium Series 8GP140-3H

Technical Specifications

kW output – pool *1	140
kW output – spa *2	95
kW input	28.0
Power Supply	3 Phase + N & E
Curcuit Breaker – 3 Pole D Curve	80 amps
Nominal compressor run amps	24.5/Phase (x2)
Fan full load amps	1.35/Phase (x4)
Recommended flow rate – litre/second	6
Water connections	Application Specific
Dimensions LxWxH – mm *5	2300 x 1330 x 2278
Weight – kg	1100
Air volume @ high speed litre/second	11,000

NB: Designs and specifications are subject to change without notice.
 *1 kW output values are nominal ratings based on 18°C wet bulb and 28°C water temperature.
 *2 kW output values are nominal ratings based on 8°C wet bulb and 38°C water temperature.
 *3 Sound pressure measured at 3m in decibels re 20 µPa.
 *5 Dimensions will vary with placement position of the electrical box.

SWIMMING POOL SIZING CHART EXTENDED SEASON*

Coastal North Island*	Central North Island/ South Island*
Commercial ⁴ Surface Area (m ²)	Commercial ⁴ Surface Area (m ²)
438	372

* Extended season, New Zealand, mid-October to mid-April.
 *4 Commercial – pool must be covered when not in use (up to 12 hours per day).

Why buy from Hot Water Heat Pumps Ltd

Back up and service: You can be assured of unprecedented after-sales service. We provide free telephone and email support on all products, for the life of the product, even if you're outside of the warranty period. With periodic maintenance, your Hot Water Heat Pumps Ltd's product will provide you with a lifetime of efficient hot water heating.

Warranty: All of our commercial heat pump pool heater models carry a comprehensive two year parts and labour warranty, including the compressor, evaporator coils, heat exchanger and refrigeration systems. The titanium tube within the heat exchanger is covered against corrosion for 10 years.



Safety first: Our heat pump water heaters are fitted with protection systems to prevent damage in the event of a malfunction. Such as a flow switch to ensure the heat pump cannot operate without water flow and other refrigeration safeties. If a problem is identified, the unit automatically shuts down before damage can occur.

Energy efficient: Government agency EECA (Energy Efficiency Conservation Authority) has listed heat pumps as one of the most energy efficient forms of heating in New Zealand.

Clean and green: Our heat pumps only use electricity to capture thermal energy in the air, and therefore produce no direct emissions. Compared to gas and diesel boilers, our heat pumps can reduce total carbon emissions by up to 90%.

INSTALLATION INSTRUCTIONS

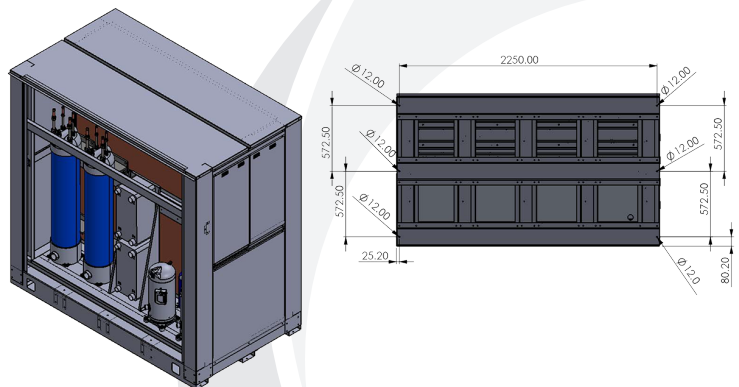
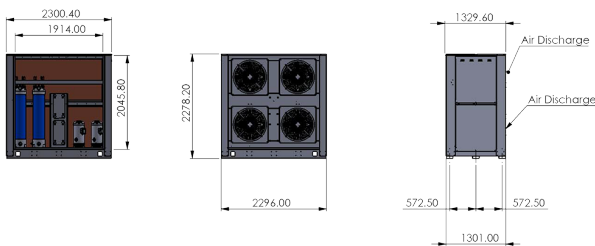

Note: 8G R32 Series heat pumps and chillers are not suitable for indoor/plant room installations without air quality monitoring and ventilation due to mild flammability.

3 Corban Avenue, Henderson, Auckland 0612
 PO Box 21 586, Henderson, Auckland 0650
 Phone 09 838 9444 Fax 09 838 6223
 info@waterheating.co.nz

HOT WATER HEAT PUMPS LTD
 Advancing Water Heat Pump Technology SINCE 1980