



# HOT WATER HEAT PUMPS LTD

Advancing Water Heat Pump Technology

SINCE 1980



## TH-260D1

### All in One Heat Pump Manual



# Contents

- 1. Safety Warnings..... 4**
- 2. Parts and Construction..... 6**
  - 2.1 TH-2680D1 Dimensions..... 6
  - 2.2 TH-2680D1 Schematic..... 7
- 3. Installation Instructions ..... 8**
  - 3.1 Delivery ..... 9
  - 3.2 Installation Location Requirements..... 10
  - 3.3 Base Requirements..... 11
  - 3.4 Airflow..... 13
  - 3.5 Noise Considerations ..... 14
- 4. Plumbing Schematics..... 15**
  - 4.1 TH-260D1 Connection Dimensions and Components..... 15
- 5. Plumbing Installation..... 16**
  - 5.1 Plumbing Connections ..... 16
  - 5.2 Cold Water Inlet..... 16
  - 5.4 Condensate Drain..... 16
  - 5.5 Temperature and Pressure Relief (TPR) Valve..... 17
  - 5.6 Tempering Valve..... 18
  - 5.7 Expansion Control Valve (ECV) ..... 18
  - 5.8 Pressure Reducing Valve (PRV) ..... 19
  - 5.9 Isolation Valve..... 19
  - 5.10 Filling the System..... 19
- 6. Electrical Connection..... 20**
  - 6.1 Electrical Schematic ..... 20
  - 6.2 Regulations and Preparations..... 21
  - 6.3 Hard Wiring a THD-260D1 ..... 21
- 7. Commissioning TH-260D1..... 22**
  - 7.1 Pre-Commissioning Checks and Procedures..... 22
  - 7.2 Checklist..... 23

|   |           |
|---|-----------|
| <b>8. Operational Panel .....</b>                           | <b>24</b> |
| 8.1 Key Factors .....                                       | 24        |
| 8.2 Accessing Display Screen .....                          | 24        |
| 8.3 Control Interface .....                                 | 25        |
| 8.4 Control Interface Icons .....                           | 26        |
| 8.5 Unlocking and Turning the Unit On .....                 | 29        |
| 8.6 Setting.....  | 30        |
| 8.7 Setting Up the Timer .....                              | 31        |
| 8.8 Error Handling .....                                    | 34        |
| <b>9. Troubleshooting.....</b>                              | <b>35</b> |
| 9.1 No Hot Water at Tap .....                               | 35        |
| 9.2 Hot Water Runs Out .....                                | 36        |
| 9.3 Large Amounts of Water Going into Drain.....            | 37        |
| 9.4 Changing the Hot Water Temperature .....                | 37        |
| 9.5 Low Water Pressure.....                                 | 37        |
| 9.6 Function Parameters .....                               | 37        |
| <b>10. FAQs .....</b>                                       | <b>38</b> |
| <b>Warranty Information.....</b>                            | <b>40</b> |
| <b>Warranty Registration Installation Declaration .....</b> | <b>42</b> |

# 1. Safety Warnings



## INSTALLATION & OPERATION

**WARNING** –This unit stores hot water up to 60°C that can cause scalding. DO NOT touch any of the hot water pipes or fittings. Children MUST always be supervised around the unit to avoid serious injuries.

- DO NOT install or operate this unit before reading the manufacturer's instructions.
- The system is for OUTDOOR USE ONLY. According to AS/NZ 5149, it's outdoor installation site shall be positioned to avoid refrigerant leaking into the building or endangering people
- This unit must be installed, commissioned, serviced and operated by an authorised person with the appropriate knowledge and experience in accordance with all applicable local rules and regulations. Where necessary, the relevant electrical and plumbing work will need to be certified to the satisfaction of the local regulatory authorities.
- This unit must be installed, operated, and maintained in accordance to the manufacturer's instructions to ensure safe operation throughout its' lifespan.
- This unit is not intended for use by persons without the ability or knowledge in operating the unit, such as children. Children should always be supervised around the unit. They MUST NOT play with the unit.
- The removal or alteration of any components and electric element cover in the unit MUST only be performed by a qualified person such as a certified electrician. Removing the cover will expose 230 V wiring that can cause shock and serious injuries.
- Installation MUST comply with AS/NZS 3000.
- If the unit power supply cord is damaged, it MUST BE replaced by a qualified person.
- DO NOT touch power connections.
- Avoid touching exposed pipework and fittings connected to the unit because they can be HOT.
- DO NOT store items on top of or against the unit.
- Maintain the necessary clearances on all sides of the unit to ensure continued safe operation.
- DO NOT operate unless all of the covers are secured in place.
- DO NOT operate the unit unless the hot water cylinder is full of water.
- Due to the nature of stainless steel in an outdoor environment, staining and discolourisation are expected



#### **RISK OF FIRE**

- The unit uses R290 (propane) refrigerant, a class 3 flammable gas according to AS/NZS ISO 817. The refrigerant can only be handled by a refrigeration technician with the appropriate refrigerant handling license.
- If refrigerant leaks, there is a possibility of fire with an external ignition source.
- DO NOT store chemicals or flammable materials near the unit.
- DO NOT place the unit near any ignition sources.
- DO NOT use a flammable spray such as hair spray, paint, etc. near this unit as this may cause a fire.

For any inquiries, please contact:  
**Hot Water Heat Pumps Ltd (HWHP) at 0800 33 66 33**

# 2. Parts and Construction

## 2.1 TH-2680D1 Dimensions

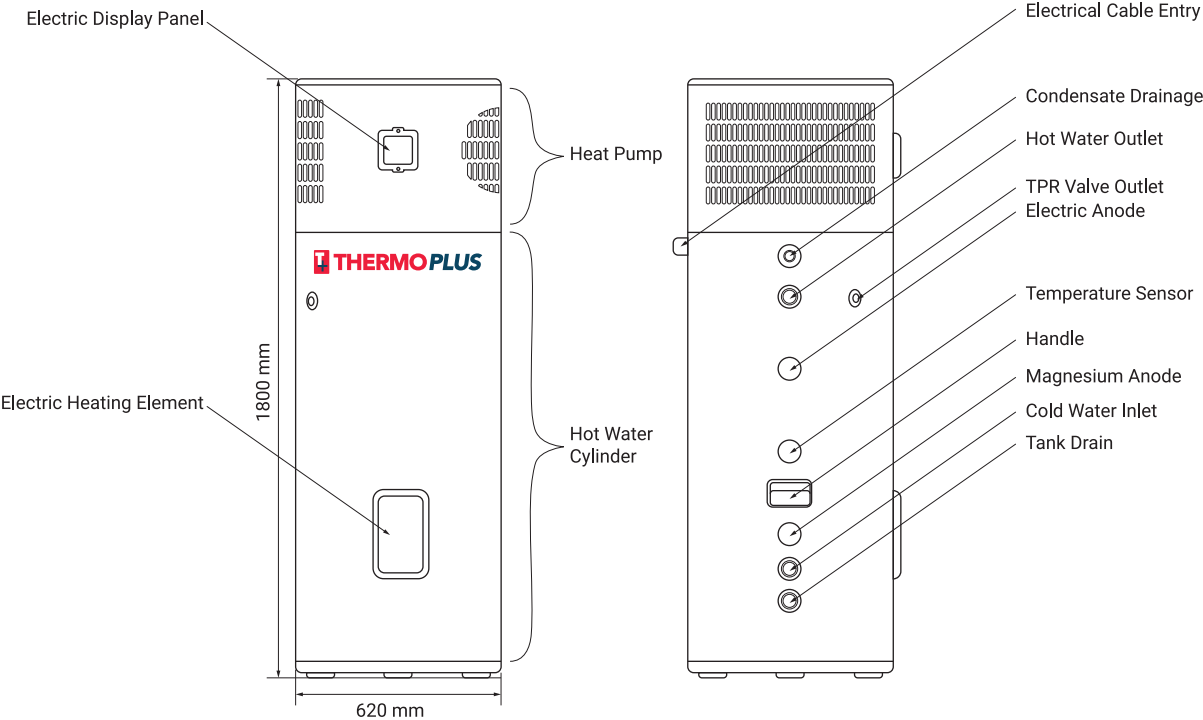
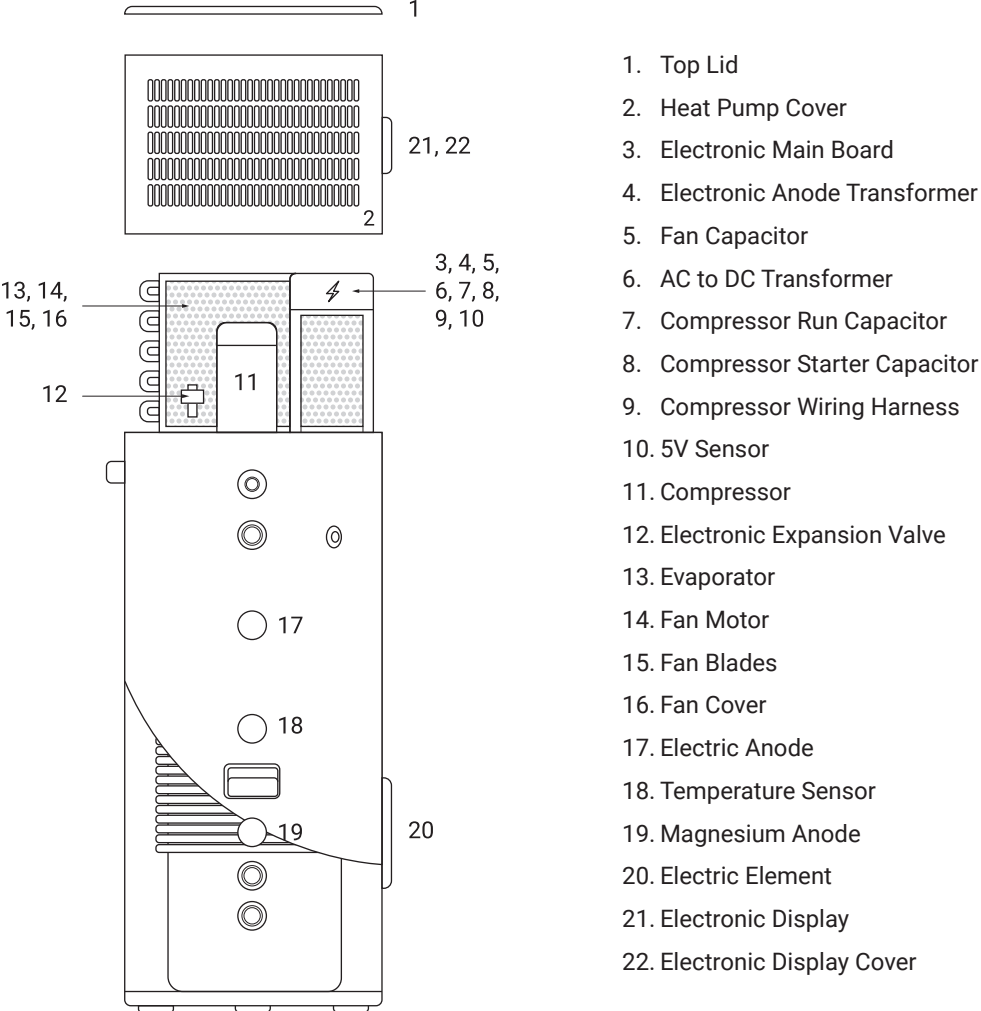

Figure 1: TH-260D1 (Exterior)



The unit uses R290 (propane) refrigerant, a class 3 flammable gas according to AS/NZS ISO 817. The refrigerant can only be handled by refrigeration technician with the appropriate refrigerant handling license. If refrigerant leaks, there is a possibility of fire with an external ignition source.

## 2.2 TH-2680D1 Schematic



**Figure 2: TH-260D1 (Interior)**

### 3. Installation Instructions

All THD-260D1 heat pumps are designed for installation by a licensed plumber in accordance with standards set out in AS/NZS 3500.2.

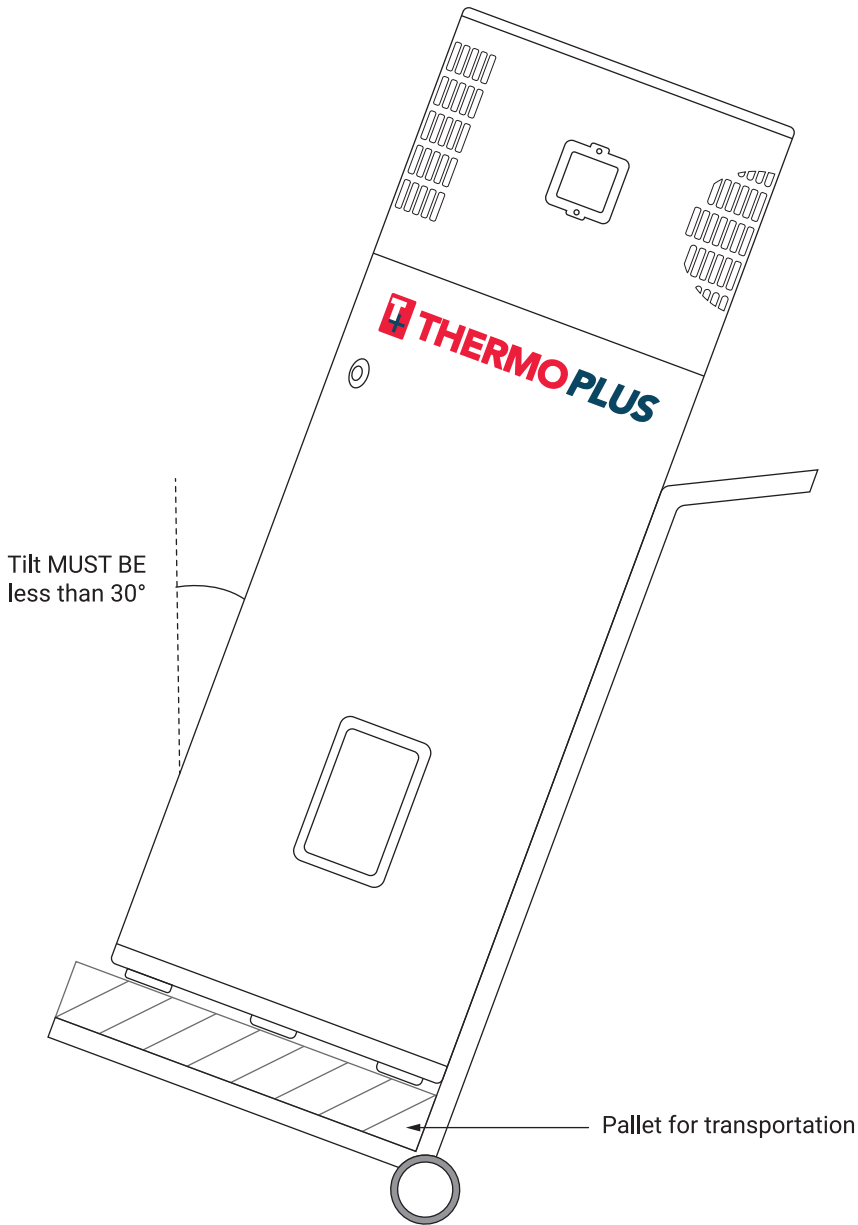

**Figure 3:** TH-260D1 Delivery Position

### 3.1 Delivery

- The TH-260D1 heat pump water heater **MUST** always maintain a near vertical position with no more than a 30° tilt from vertical. Moving or storing the unit in a horizontal position will void the warranty.
- The unit **MUST** be transported in the packaging at all times.
- The unit must be handled by at least two people at all times to avoid strain and damage. The weight of the unit and the packaging is 133kg (118kg unpacked).
- The unit should always be handled with care. Damage to the outer casing including dents and marks caused by inappropriate handling are not covered under warranty.
- According to building code G12, the unit must be adequately supported including seismic restraint. The heat pump water heater contains a 260L hot water storage tank, therefore, it must be adequately supported according to the instructions in Section 3.3.



The TH-260D1 heat pump uses a flammable gas therefore:

- The unit **SHOULD NOT** be in an area with an ignition source (e.g. open flame).
- Do not pierce or burn the unit.
- Be mindful that refrigerant leaks can cause odour.



National regulations exist for the storage, transportation and handling of hazardous goods including flammable gases. The maximum number of an configuration of the equipment permitted to be transported or stored together will be determined by the unit local regulations.

## 3.2 Installation Location Requirements

- The THD-260D1 is for OUTDOOR USE ONLY. According to AS/NZS 5149, its outdoor installation site shall be positioned to avoid refrigerant leaking to the building or endangering people.
- The installation location should have enough space for installation, servicing, and maintenance.
- The installation location should have free air-flow and be ventilated properly.
- Ensure the air inlet and outlet of the unit are not obstructed.
- The installation location must be far away from any open flames and ignition sources.
- Refer to the following sections for instructions on how to install the base, ensure sufficient air flow, and reduce the impact of the operating noise.



### NOTE

- In regions where the temperature falls below 0°C, care must be taken to avoid frost and ice formation in the pipes connected to the unit. The connecting pipes should be insulated and protected.
- The installation should avoid corrosive locations.
- Avoid installations where air can be contaminated with oil particles such as outside the kitchen.
- For installation in corrosive environments listed below, please consult Hot Water Heat Pumps Ltd to inquire about suitable treatment:
  - A. Seside with salty air.
  - B. Air with high sulphur gas concentration.

## 3.3 Base Requirements

### Fixture Requirements

- Install the unit on a stable structure that can carry 400kg or more. The supporting structure must not shift over time (due to water drainage, etc.). If using a concrete plinth, a minimum thickness of 50mm is required. If using a hardwood base, a minimum thickness of 25mm is required. If using a concrete base paver, the minimum size is 600mm square.
- Verify that all four feet of the unit lie on the base at all times to ensure stability. The warranty will be voided otherwise.
- The base must be constructed to ensure that the unit is always vertical and level as shown in **Figure 4**. This ensures that condensate can drain adequately and avoid flooding the unit. If the unit is installed with more than 3 degrees of tilt, the warranty will be voided.
- The base must provide sufficient drainage for overflow as described in AS/NZS 3500.2.
- Install a drain tray underneath the unit if water leakage could damage the property.
- The unit must be adequately supported including seismic restraint.
- The unit must be supported by the wall using two 50 x 50mm vertical blocking full height of the hot water cylinder. The two vertical blockings must be fixed to the wall framing with 100 x 3.75mm nails at 600 maximum centres. Two horizontal blocks should be fixed onto the vertical blocks at evenly spaced distances.
- A minimum clearance of 60mm between the unit and the wall must be provided to give sufficient space for the power cable to hang naturally. Ensure that the unit is installed close to power plug points to ensure security.
- The unit must also be restrained with three 25 x 1mm stainless-steel straps tensioned when fixed in place. The straps must be fixed to the wall framing with 8mm coach screws with 30 x 2mm thick washers. **Figure 4** shows the items required to adequately support the unit.
- The stainless-steel straps **MUST** secure the hot water cylinder section of the unit. The straps shall not be fastened onto the heat pump above the hot water cylinder.
- The vertical blocks and stainless-steel straps **MUST** be nailed into the timber frames in the wall to ensure compliance.
- Ensure that sufficient clearances are allowed. See **Figure 4**.

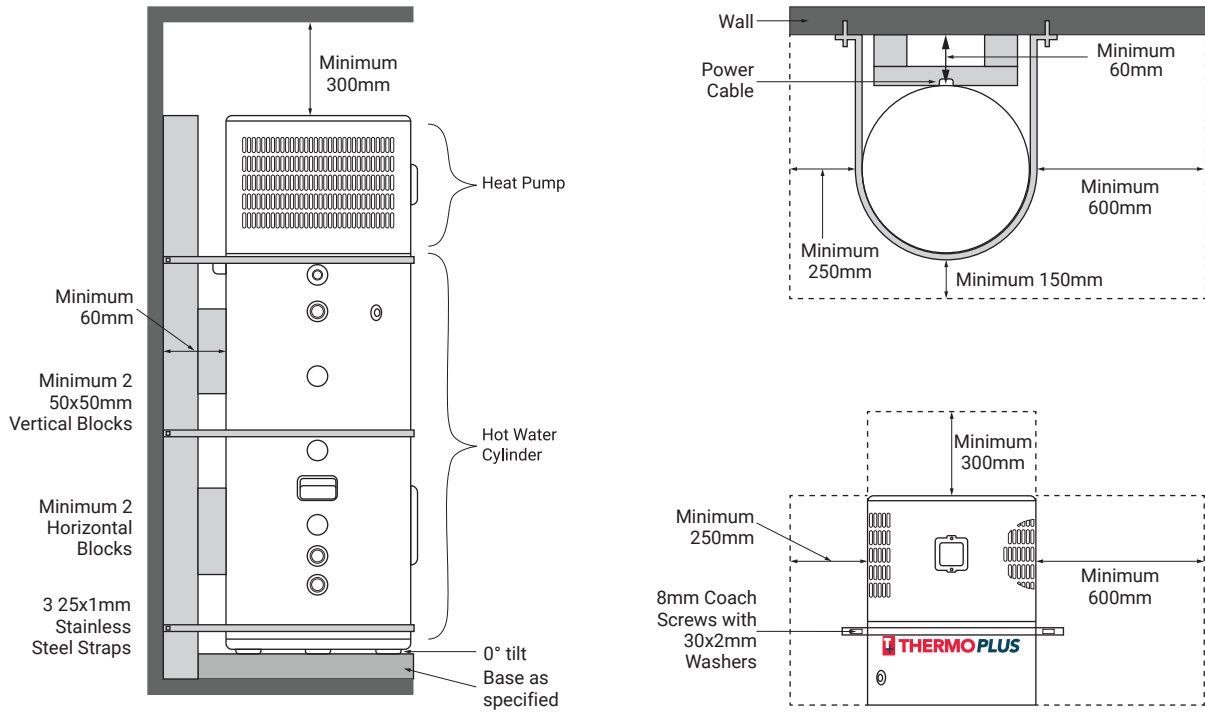

**Figure 4: TH-260D1 Installation Base Requirements and Concrete Base Example**

## 3.4 Airflow

### Airflow Requirements

- The TH-260D1 heat pump is designed for open air operation only. It requires sufficient air supply to maintain high operating efficiency.
- Allow for sufficient clearances during installation according to **Figure 4**.
- The unit must be seismically restrained in accordance with NZBC G12.
- A 600mm clearance at the air outlet and 250mm clearance at the air inlet must be present to allow for sufficient airflow. If the unit is installed under any overhead structures, a minimum clearance of 300mm is required from the top of the unit.
- Ensure that access to the electrical panel and control interface at the side of the unit is possible. If the installation clearances and requirements are not met, the owner will be responsible for the cost (including plumbing and drainage) of moving the unit when necessary. Work required to make the unit installation compliant is not covered by the warranty.
- Exceeding the recommended clearances is also strongly encouraged to allow for good airflow and easy access during maintenance.
- Note that sufficient airflow is critical to the TH-260D1 heat pump performance. Failure to allow for sufficient airflow can cause a significant reduction in performance which can lead to excessive energy consumption.
- Avoid installation in areas with a high risk of clogging the air inlets and outlets of the unit.
- Avoid installing the unit in or near areas with falling leaves because this can block the air vents and potentially damage the unit.
- Avoid installing the unit between multiple walls or structures for best performance.



TH-260D1 systems are designed for open air use only with 20m<sup>3</sup> or more of unobstructed space surrounding the unit.



Ensure that the installation location complies with the requirements of AS/NZS 5149 in regards to the heat pump containing a flammable refrigerant.



The electrical access point and display panel should always be accessible.

### 3.5 Noise Considerations

- Ensure that the installation location complies with the local noise regulations regarding neighbouring properties. In New Zealand, Section 16 of the Resource Management Act 1991 should be referenced.
- The built-in TIMER function can be used to limit the units operating hours to the owner's desired hours to reduce noise concerns. Should the TH-260D1 be audible from within the residence when operating, the unit should be run in TIMER mode.
- Avoid installing the unit adjacent to bedrooms and areas where noise is a concern.
- Ensure that the power cable connected to the unit has sufficient space to come out of the vertical blocking.



When installing the unit, do not install less than 3 metres from a neighbour's window or door other than a garage door or shed.



If you are experiencing noise issues with your TH-260D1, please contact Hot Water Heat Pumps Ltd directly. There are means to address the sound produced when the unit is operational.

# 4. Plumbing Schematics

## 4.1 TH-260D1 Connection Dimensions and Components

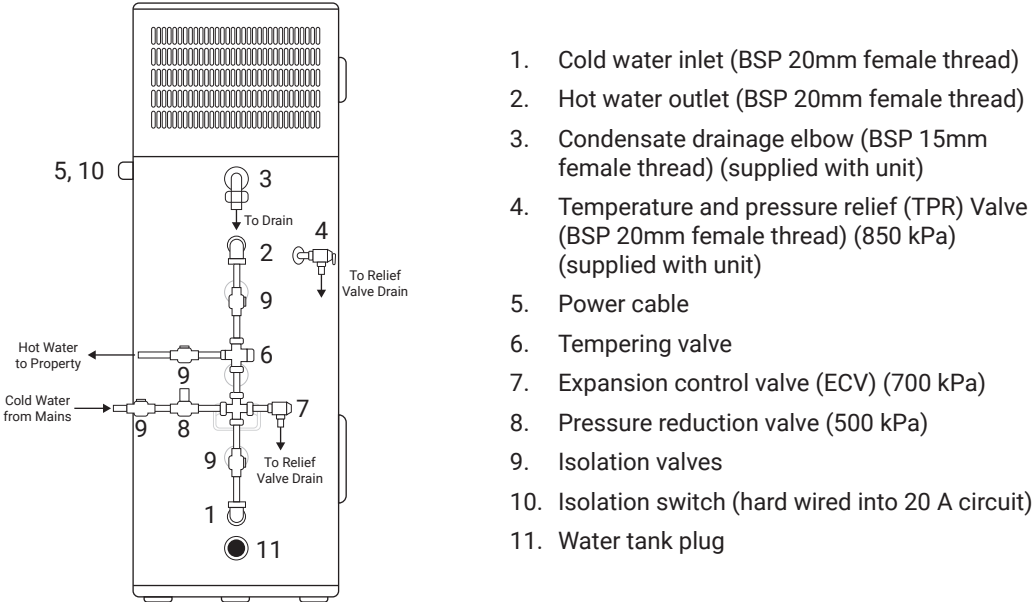

**Figure 5: Plumbing Connections**



These plumbing instructions and schematics reference standards covered under G9 and G12 of the Building Code and represent an ideal installation procedure for the unit. Where applicable, other local regulations should be considered.

## 5. Plumbing Installation

### 5.1 Plumbing Connections

- All required plumbing should be installed and fitted by an authorised plumber. The unit must be installed according to building code G12 water supplies.

### 5.2 Cold Water Inlet

- 20mm BSP female connection.
- This port can also be used to drain the hot water storage tank.
- If the ambient temperature at the installation location drops below 0°C, insulate all water pipes and connections with a minimum of 13mm closed cell insulation to prevent freezing.

### 5.3 Hot Water Connections

- 20mm BSP female connection.
- INSULATE ALL HOT WATER LINES with a minimum of 13mm closed cell insulation to minimise heat losses. This includes all water fittings.
- Only the recommended water pipe systems should be used for plumbing and the unit.
- All hot water supply parts must comply with AS/NZS 3500.4 and G12/AS1. Recommended piping systems are copper, polybutylene (Buteline) and PEX systems.

### 5.4 Condensate Drain

- During normal operation, condensation occurs in the heat pump as the air flow across the evaporator coil is cooled. In locations with humidity greater than 80%, up to 5 litres per day can be expected.
- The unit has a built in condensate tray above the water storage tank to collect the condensate. Overflow from this tray flows out through the condensate drainage elbow and is discharged through the condensate drain line.
- The ½" copper condensate drainage elbow must be connected to the nearest approved stormwater drain. The condensate should be collected in an open dish and discharged through copper piping. Improper drainage will cause algae and moss growth.

- The condensate line **MUST** flow in a downward direction to enable the gravity fed condensate drainage to flow down. **DO NOT** couple the condensate line with the discharge line connection to the TPR valve.
- Care should be taken to reduce the risk of blocking the condensate flow.



Connecting any pipe directly to the condensate line without an air gap will void the warranty.



Do not tighten the condensate drainage elbow with tools. Hand tighten only.

## 5.5 Temperature and Pressure Relief (TPR) Valve

- Valve rated capacity: 850kPA.
- Set temperature: 93–99°C.
- A TPR valve must be installed to ensure safe operation. Failure to do so can potentially cause injury and damage to the unit.
- The unit is supplied with a suitable TPR valve. If a TPR valve is not provided, please contact your supplier.
- The supplied TPR valve must be installed on the TPR valve port (port 4 in **Figure 4**) on the unit.
- The TPR valve should be connected to a vertical discharge pipe that enables water to flow downwards at all times.
- The TPR discharge pipe outlet must be open to the atmosphere at all times.
- The TPR discharge pipe outlet should be positioned such that the outlet hot water can not cause injury to persons or damage to the building.
- The TPR valve should be insulated with a minimum of 13mm close cell insulation to reduce heat loss.



### IMPORTANT

A discharge pipe connected to the TPR valve must be installed in a vertical position and in a frost-free environment.

#### Warning:

- The discharge line connected to the TPR valve SHOULD NOT be connected to the condensate drainage line.
- Water can drip from the discharge pipe connected to the TPR valve. This pipe must be left open to the atmosphere.
- The TPR valve should be operated regularly to prevent the formation of lime deposits and to verify that it is not blocked. The lever on the valve should be lifted gently every 6 months to check for water flow.

## 5.6 Tempering Valve

- A tempering valve must be installed on the unit to comply with AS/NZS 3500.4 as the unit produces hot water at 60°C to stop the growth of Legionella bacteria. The tempering valve should be connected to the hot water supply lines to avoid exceeding safe water temperatures.
- The tempering valve installation should be easily accessible for maintenance.
- A high-performance tempering valve is recommended to maintain a consistent hot water supply temperature. The tempering valve is NOT supplied with the unit.



Any hot water cylinder with an anode can produce flammable hydrogen gas when it is left running for an extended time without using the hot water. For example, this can occur after a holiday where the property was not occupied for an extended period.

To ensure your safety, it is recommended to run a hot water tap for several minutes to remove any potential gas built up in the hot water cylinder. Please do not smoke or have naked flames present during this time as these gases are flammable. Provide sufficient ventilation to prevent gas build up where the open hot water tap is located.

## 5.7 Expansion Control Valve (ECV)

- An ECV must be installed as AS/NZS 3500.4 requires installation of an ECV for hot water storage tanks with unvented cylinders.
- The ECV drain pipe MUST NOT have any restrictions. The outlet of the drain pipe should discharge into the atmosphere. The outlet should be fully open at all times.

- The ECV drain pipe outlet should be positioned such that the outlet hot water cannot cause injury to persons or damage to the building.
- The drain should be sized to enable water runoff when the safety valve is fully opened.
- The ECV should be rated at a maximum of 700 kPa. for an 850 kPa TPR valve setting, the ECV should be set to 700 kPa.

## 5.8 Pressure Reducing Valve (PRV)

- A pressure reducing device, such as a PRV, MUST BE connected to the mains cold water supply (point 8 in **Figure 4**).

## 5.9 Isolation Valve

- An isolation valve must be installed in the cold water supply line to the unit.
- An isolation valve must also be installed on the hot water outlet line. This isolates the hot water system from the rest of the water supply to the household. This is important to avoid disrupting the household water supply when servicing, draining, maintaining, and replacing the unit. Refer to **Figure 4** for all the locations where an isolation valve must be installed.
- The isolation valve can be combined with a PRV valve.

## 5.10 Filling the System

- Once the TH-260D1 has been connected in accordance to Sections 3 and 4 of this manual, the tank can be filled and pressurised.
- Ensure at least one hot water tap is open inside the property to allow air to escape from the tank. This is called “bleeding or priming the system” and it ensures that no air pockets remain. Make sure that all air in the unit is removed during the filling process.
- Open the non-return valve at the cold-water inlet to start filling the unit with cold water. Once water begins running out of the hot water tap, the system is completely primed. The tap can then be turned off.
- Always ensure that the tank is completely full before connecting and turning on electricity supply. Double check to ensure that the tank is completely full.
- If the tank is full, connect and turn on the electricity supply.

## 6. Electrical Connection

### 6.1 Electrical Schematic



Installation of the TH-260D1 heat pump to the power supply should only be carried out by qualified electricians in accordance with the following instructions.

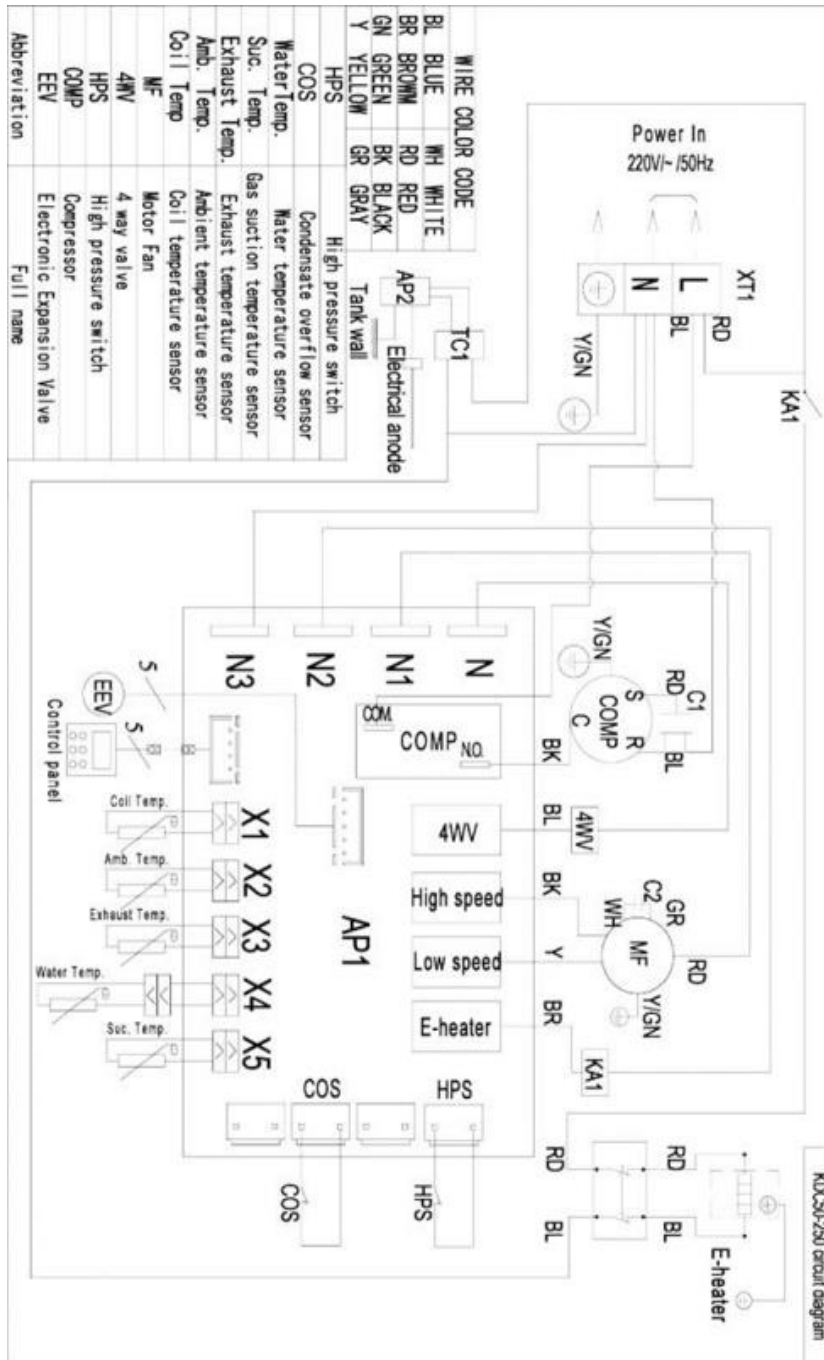

Figure 6: Electrical Schematic

## 6.2 Regulations and Preparations

Ensure the unit is electrically isolated from the power supply before starting work.

The TH-260D1 heat pump is designed to be permanently wired to a single-phase 220-240V 50Hz AC supply.

All work must comply with AS/NZS 3000 and any local supply authority regulations.

The unit is rated for 20 A. A suitable circuit breaker must be fitted on the power supply.

To access the electrical works, the electrician should remove the connecting screws on the cover and pull the cover up from the rest of the unit.

The heat pump is fitted with a thermal cut out. This safety device **MUST** be connected to the circuit whenever the heat pump is operational. Operation of the cut out indicates a potentially dangerous situation. Replacement and resetting of the cut-out must only be carried out by a qualified electrical technician.

Per AS/NZS 60335-1 Clause 7.12.2, the fixed wiring must have the ability to be disconnected incorporated in accordance with wiring rules.

FUSE: 250V, T3.15 A

## 6.3 Hard Wiring a THD-260D1

The THD-260D1 must be permanently wired into a 20A circuit with an isolator. A suitable circuit breaker must be fitted on the power supply.

The junction box is required to be rated for outdoors and fitted with an isolator switch, such as in the example shown in the diagram on the right.

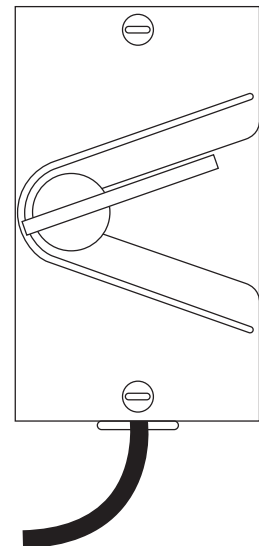

If the power cord is damaged, it must be replaced by either the manufacturer, a service agent or similarly qualified person in order to prevent an electrical hazard.



The unit installation must comply with AS/NZS 3000 wiring regulations.

## 7. Commissioning TH-260D1

### 7.1 Pre-Commissioning Checks and Procedures

- Once electrical and plumbing connections have been completed by a qualified tradesperson, the system is prepared for operation.
- Ensure the storage tank is full before turning on the system.
- Priming the system must be done through a hot water tap. Don't use the TPR valve alone as air pockets will still be present in the system between the unit and the taps.
- Ensure that the unit sits on a flat, smooth concrete block/hardware base and that there is a drain installed from the condensate port to an appropriate drain point.
- Ensure all water pipes and water fittings have closed cell insulation applied to minimise heat loss.
- Ensure that the air inlet and discharge are kept clear to allow air to flow freely.



**WARNING:**

This unit should not be used by anyone (children included) with a lack of knowledge, ability and experience without supervision and instruction on use of the unit by a responsible person. Supervise children to ensure they don't play with the device. Install the unit in accordance with national wiring regulations.

## 7.2 Checklist

- The TH-260D1 is positioned on a level surface.
- The TH-260D1 is installed on a stable structure which can hold more than 400kg.
- A minimum of 300mm distance is available above the TH-260D1 to allow removal of the lid for maintenance (see Section 3.4 Air Flow).
- A minimum of 600mm distance on the fan discharge side and 250mm minimum on the air intake side of the TH-260D1 is provided for air flow (see Section 3.4 Air Flow).
- A minimum of 150mm is provided between the exterior of the tank and any obstructions/walls to provide space for air circulation and servicing (see Section 3 Air Flow).
- The condensate drainage elbow is hand tightened (see Section 4.1 TH-260D1 Connection Dimensions and Components).
- The drain from the condensate drainage elbow is free flowing and is not connected directly to any other pipeline or TPR valve (see Section 4.1 TH-260D1 Connection Dimensions and Components).
- The purpose of the tempering valve has been explained to the customer. Valves are fitted on the water inlet and outlet to the unit. Unit is set to 60°C.

Once the system is installed, the installer must sign below to ensure compliance with all procedures, otherwise the warranty may be void.

Installer Full Name

Date

Signature of Installer

Once you have carried out all these checks you are ready to switch on the unit.

## 8. Operational Panel

### 8.1 Key Factors

- The units TIMER MODE is strongly recommended to save energy and reduce noise. Set-up the TIMER MODE according to Section 8.5 and your hot water usage pattern. If your household has a large hot water demand, turn TIMER MODE off.
- The unit heats water to 60°C in the storage tank to prevent Legionella bacteria growth.
- The heat pump's heating cycle will turn on automatically when the hot water storage drops below 55°C.

*Any issue or queries? Please contact Hot Water Heat Pumps Ltd on 0800 33 66 33*

### 8.2 Accessing Display Screen

The display screen is protected by a stainless steel cover as shown on page 6.

#### To access the display screen:

1. Unfasten the thumb screws at the top and bottom of the display by turning them counter-clockwise as shown in Figure 7 below. Store the thumb screws safely.
2. Remove the cover slowly and store it safely.

#### To reattach the screen cover:







1. Place the display cover over the display screen and align the screw holes.
2. Fasten the thumb screws by rotating them clockwise using your hands only. Make sure that the screws are finger-tight to protect the display screen properly.



Always make sure to reinstall the display cover after accessing the display screen. Failure to do so will expose the screen to the elements and damage the screen and will void the warranty.

### 8.3 Control Interface

The control interface of the TH-260D1 is located at the front of the unit as shown in the figure below. The control interface is used to operate your TH-260D1 hot water system. The figure below shows the name of the buttons on the control panel. All following instructions in the manual will refer to these buttons.













| Button          | Symbol  | Key Feature  |
|-----------------|---|--|
| 1 ON/OFF button |    | Press to turn on/off display.  |
| 2 UP arrow      |    | Press to increase values.  |
| 3 DOWN arrow    |    | Press to decrease values.  |
| 4 Heat/Chill    |    | Not functional for this model.   |
| 5 Clock         |  | Press to set up internal clock. Press to switch between HOURS and MINUTES.<br>Press and hold for four seconds to setup TIMER MODE. Press again to edit the time. |
| 6 AUTO/MANUAL   |  | Press to switch between AUTO and MANUAL. Please leave it at manual unless trouble shooting.  |



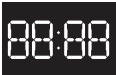













*Figure 7: Control Interface*

## 8.4 Control Interface Icons

The TH-260D1 control interface displays various icons to help you identify the status of your unit. The table below shows the meaning of all the icons. All following instructions in this manual will refer to these icons.

| Icon  | Status   | Feature   |
|---|----------|---|
|    | Lit      | Unit is on.   |
|    | Unlit    | Unit is off.  |
|    |          | Indicates the tank set point.   |
|    |          | Indicates the tank water temperature.   |
|   | Lit      | Unit is in heating mode.  |
|  | Lit      | Unit is FAULTY and needs repair.  |
|  | Lit      | Unit is in AUTO mode (NOT RECOMMENDED)  |
|  | Unlit    | Unit is in MANUAL mode (RECOMMENDED)  |
|  | Lit      | Heat pump is ON and defrosting.   |
|  | Flashing | Heat pump is ON and in defrost delay. This is NOT a fault or error.                                     |
|  | Flashing | Heat pump is OFF and in refrigerant recovery during decommissioning. This is NOT relevant to end-users. |
|  | Lit      | Electric Heater is ON to support the heat pump.   |
|  | Flashing | Electric Heater is ON to disinfect the water.   |

| Icon  | Status   | Feature   |
|---|----------|---|
|    |          | Displays the water temperature  |
|    | Lit      | Currently showing Celsius temperature.  |
|    |          | Displays the internal system clock time.  |
|    | Lit      | TIMER MODE is ON.   |
|    | Unlit    | TIMER MODE is OFF.  |
|    | Flashing | TIMER MODE is in setting mode.  |
|   | Lit      | Unit is ON during TIMER MODE.   |
|  | Unlit    | Unit is OFF during TIMER MODE.  |
|  | Flashing | Ready to set TIMER MODE unit "ON" times. This is the heating period start times.                                      |
|  | Lit      | Unit is OFF during TIMER MODE.  |
|  | Unlit    | Unit is ON during TIMER MODE.   |
|  | Flashing | Ready to set TIMER MODE unit "OFF" times. This is the heating period end times.                                       |
| 1   | Lit      | Ready to set START and END times for "ON" period 1.<br>If not setting up TIMER MODE, the unit is in heating period 1. |
| 2   | Lit      | Ready to START and END times for "ON" period 2.<br>If not setting up TIMER MODE, the unit is in heating period 2.     |

| Icon  | Status | Feature   |
|---|--------|---|
| 3   | Lit    | Ready to set START and END times for "ON" period 3.<br>If not setting up TIMER MODE, the unit is in heating period 3. |
|  | Lit    | The control panel is LOCKED.  |
|  | Unlit  | The control panel is NOT LOCKED.  |

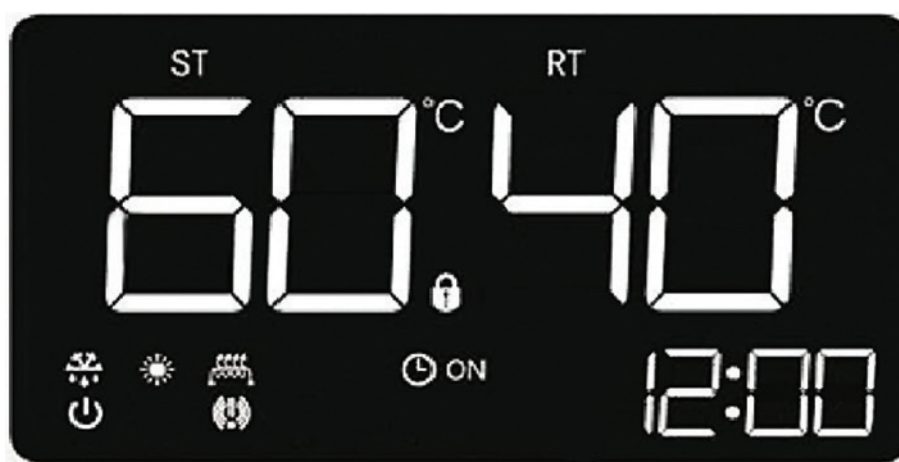

## 8.5 Unlocking and Turning the Unit On

1. Press the ON/OFF button once to unlock the control interface. The screen will brighten and the "LOCK" icon will turn off to indicate that the control interface is unlocked.



When the lock symbol is present, pressing any button once will unlock the controller interface.

2. Press and hold the ON/OFF button for *four* seconds to start the water heating cycle. The sun symbol will flash for a few seconds and then become stable, indicating that the unit is in heating mode.



## 8.6 Setting

The TH-260D1 unit relies on the internal clock to operate the TIMER MODE. Please set the internal clock correctly to ensure the unit operates correctly. Every step will hold for five seconds before returning to the home screen. **Note that the time is displayed in the 24-hour format. Also note that the time does not change with daylight savings.**

1. Press the CLOCK button to begin setting the time. The hour value at the bottom right of the display will start flashing.



2. Use the UP or DOWN button to adjust the flashing hour value to the correct time (example hour is changed from "12" to "13"). When ready, press the CLOCK button to toggle the minute value.



3. Use the UP or DOWN button to adjust the flashing minute value to the correct time (example minute set to "34").



4. When ready, press the CLOCK button to finish setting the clock.



If the display time is within the "ON" time periods defined by the TIMER mode, the "ON" symbol will be displayed next to the "CLOCK" icon on the display. If the time is outside "ON" time periods defined by the TIMER mode, the "OFF" symbol will be displayed next to the "CLOCK" icon on the main display.

For example (using factory default timers):

Time = 09:00 →  ON

On Time = 19:00 →  OFF

## 8.7 Setting Up the Timer

**The unit comes with a built-in TIMER MODE that is easy to set up. It is highly recommend for the following reasons:**

1. The TIMER MODE can reduce electricity consumption significantly. The heat pump water heater operates more efficiently during the day when the ambient temperature is higher.
2. The TIMER MODE can help reduce noise during off hours. The TIMER MODE will make sure that the system does not turn on unnecessarily when hot water is not required in the household.

**Before setting up the TIMER MODE, you need to determine the following factors:**

1. Hot water usage pattern: Estimate and determine your hot water usage peak times. Normally this occurs when most people in the household are taking showers. Outside the peak times, hot water will still be available as heated water is stored in the tank.
2. Temperatures and Climates: MAKE SURE to allow sufficient time for the unit to heat up the water before the peak usage. In New Zealand's climate, it is usually sufficient to turn on the unit two hours before the peak times.

**TIMER MODE set up notes:**

- The CLOCK icon on the interface indicates that the timer mode is active.
- You can set up to three heating periods. the number (1, 2, or 3) next to the CLOCK icon indicates the heating period number.
- The ON icon next to the CLOCK and numbers symbols indicates that the heating is ON. When setting up the timer, the "ON" icon indicates the heating period's START time.
- The OFF icon next to the CLOCK and number symbols indicates that the heating is OFF. When setting up the timer, the OFF icon indicates the heating period's END time.
- Set the start and end times of heating periods 2 and 3 to 00:00 if you only require one heating period.

### To set up and use the TIMER MODE:

1. Press and hold the CLOCK button for four seconds to start setting up the TIMER MODE. the CLOCK and "1" icons will illuminate. The ON icon will start flashing to indicate that the TIMER MODE settings are ready to be edited.



2. The "1" indicates that you are setting heating period 1. The ON indicates that you are setting the period start time.



3. Use the UP and DOWN buttons to set the hour value. When finished, press the CLOCK button to switch to the minute value. Use the UP and DOWN buttons to set the minute value.



4. Press the CLOCK button to set the heating end time. The OFF icon will light up, and the ON icon will fade.



5. Use the UP and DOWN buttons to set the hour value. Press the CLOCK button to switch to the minute value. Use the UP and DOWN buttons to set the minute value.



6. Press the CLOCK button to switch to the next heating period. The "1" and OFF icons will face. The "2" and the ON icons will light up, indicating that you are setting the start time for heating period 2.



7. Repeat sets 3 to 5 to set heating period 2. Press the CLOCK button to set period 3. Repeat steps 3 to 5 to set heating period 3.

**Note:** Set periods 2 and 3 to start and end at 00:00 if you only want one heating period.



8. When finished, press the ON/OFF button once to finalise the TIMER MODE. The CLOCK and ON or OFF icons will stay lit, indicating that the unit is in TIMER MODE.



The factory default for the in-built timer period is 09:00 – 18:00.



For further information about setting timers, please contact Hot Water Heat Pumps Ltd.

## 8.8 Error Handling

The TH-260D1 unit will display an error code on the bottom right corner when a fault has occurred. The error message will show where the time is usually displayed as well as the error symbol. Please note the error code before contacting Hot Water Heat Pumps Ltd as soon as possible.



Errors that prevent the heat pump from operating normally will cause the unit to heat water using the electric elements. The ELECTRIC HEATER icon will be illuminated when this occurs.

When an error persists, please note the error codes below and contact Hot Water Heat Pumps Ltd on 0800 33 66 33.

| Error Code | Name   |
|------------|--|
| 01         | Water flow switch disconnect                 |
| 02         | Water temperature too high                   |
| 03         | High-pressure switch failure                 |
| 04         | Low-pressure switch failure                  |
| 09         | Communication failure                        |
| 11         | Evaporator coil temperature sensor failure   |
| 12         | Ambient temperature sensor failure           |
| 13         | Exhaust temperature sensor failure           |
| 14         | Water inlet temperature sensor failure       |
| 15         | Tank temperature sensor failure              |
| 17         | Absorb temperature sensor failure            |
| 19         | Return water temperature sensor failure      |
| 20         | Outlet water temperature too high protection |
| 21         | Outlet water temperature too low protection  |

## 9. Troubleshooting

### 9.1 No Hot Water at Tap

| Possible Causes   | Checks   | Solution  |
|---|--|---|
| The unit is not heating the water and has no power.     | Check the control screen to see if it is illuminated.  | If there is a blank screen, check that the power supply switch is turned on and that the house fuses have not tripped.  |
| An issue with the home's tempering valve.               | Check the temperature of the hot water out of the taps.  | If the tank temperature is reading higher than the temperature at your taps, contact your installing plumber to service/replace the home's tempering valve.   |
| A faulty Tank Water Temperature Sensor.                 | Check control screen to see if the Tank Temperature Sensor is showing two lines or temperature value exceeds 70°C. | Turn off power to the system for <i>one</i> minute to reset. If there is an error when power is switched back on, contact Hot Water Heat Pumps Ltd on <b>0800 33 66 33</b> to arrange a service.                                      |
| There is a problem with the system controller settings. | Check the Power on Button is showing on the controller screen.   | Press and Hold the M and UP button for <i>five</i> seconds. This will turn on the electric element to heat the water to 60°C. If the problem persists, contact Hot Water Heat Pumps Ltd on <b>0800 33 66 33</b> to arrange a service. |

## 9.2 Hot Water Runs Out

| Possible Causes             | Checks  | Solution   |
|-----------------------------|---|--|
| Shower heads are high flow. | Either check with plumber to confirm shower heads or measure flow rate with a bucket. | Arrange with a plumber to install low flow shower heads or flow valves to reduce hot water usage |
| Unit is operating on timer. | Check the control screen to see if clock symbol is illuminated.                       | Press and hold the clock button for <i>three</i> seconds to turn off the timer.                  |
| The system has an error     | Check controller screen for any error code on display.                                | Make note of the error code and call Hot Water Heat Pumps Ltd on <b>0800 33 66 33</b> .          |

*If the issues above are fixed and there is still a problem with hot water, contact Hot Water Heat Pumps Ltd on **0800 33 66 33** during working hours for assistance.*

### 9.3 Large Amounts of Water Going into Drain

It can be expected to have 5-10 litres of water drain from the unit via the condensate drain or the TPR valve while the unit is running. If more than 10 litres is being drained in a day, contact the plumber who installed the unit to check all relief valves.

### 9.4 Changing the Hot Water Temperature

All hot water systems must have a tempering valve which will set the water temperature at hot water outlets to 50–55°C. Changing the water temperature setting on the unit will not result in hotter water at the outlets. If this is required, discuss with the plumber who installed the unit for possible solutions.

### 9.5 Low Water Pressure

The water pressure at the taps is dependant on the incoming water mains pressure and any tempering or pressure reducing valves installed by the plumber. The TH-260D1 does not affect the water pressure. If the hot water pressure is significantly lower than the cold water pressure at the taps, contact the plumber who installed the system.

### 9.6 Function Parameters

To obtain the list of function parameters, please scan the QR code and fill out the form. To enter the parameter interface, press and hold the button **M** for *three* seconds.

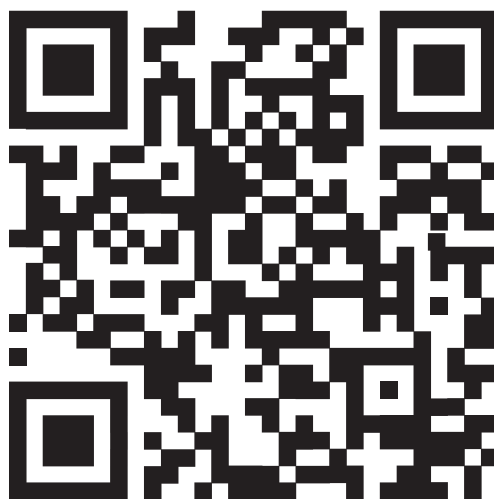

## 10. FAQs

### 10.1 What maintenance is required for the TH-260D1?

The TH-260D1 should not require additional maintenance that is not covered in the manual. The TPR valve and ECV needs to be checked for performance or replaced every 5-years or less depending on local regulations.

The levers on the TPR and ECV should be pulled once every 6-months to prevent a build up of scale. It is not recommended to alter or inspect any other parts of the hot water system.

All safety valves and magnesium anode should be replaced every 5-years to either the local agent or licensed plumber to ensure the unit continues to operate reliably and safely. In areas with high mineral content in the water (TDS greater than 600ppm) this service should happen every 3-years. In all other cases, this should be every 5-years.

### 10.2 What are the safety features of the TH-260D1?

When correctly installed, the TH-260D1 has the following safety features:

- A high temperature cut-out thermostat.
- The Temperature Pressure Relief Valve (TPR).
- Expansion Control Valve (ECV).
- A three minute delay before start up to avoid electrical damage from power surges.

### 10.3 Should I turn off the TH-260D1 when on holiday?

The heat pump can be left to operate as normal. This will ensure that Legionella bacteria doesn't grow while away. There will be only a minimal amount of electricity used in this time period.



**WARNING:**

Any Hot Water Cylinder with an anode can produce flammable hydrogen gas when it is left running for an extended time without using the hot water. For example, this can occur after a holiday where the property was not occupied for an extended period.

To ensure your safety, it is recommended to run a hot water tap for several minutes to remove any potential gas built up in the Hot Water Cylinder. Please do not smoke or have naked flames present during this time as these gases are flammable. Provide sufficient ventilation to prevent gas build up where the open hot water tap is located.

## Warranty Information

Thank you for choosing to purchase a TH-260D1 heat pump water heater. The TH-260D1 is covered by our comprehensive warranty as specified in this document.

### Warranty Claims

Please contact Hot Water Heat Pumps Ltd at 0800 33 66 33 or [info@waterheating.co.nz](mailto:info@waterheating.co.nz) for all warranty issues. Please prepare your invoice number or unit serial number for a quick and easy call.

### Warranty Period

The TH-260D1 is covered by a parts and labour warranty for the duration listed in the table below:

| Component                                 | Warranty Period |
|---|-----------------|
| Hot Water Tank                            | 6 years         |
| Refrigeration Cycle                       | 3 years         |
| Electrical Components                     | 2 years         |
| Others (Anode, TPR Valve, Elements, etc.) | 1 years         |

The TH-260D1 is covered by a parts and labour warranty for the duration listed in the table below. Hot Water Heat Pumps Ltd will cover the parts and labour cost according to the terms and conditions specified in this document for all applicable claims.

### Warranty Registration

To be able to claim this warranty, the owner must send a *completed* **Warranty Registration Installation Declaration** supplied with the product within four weeks of installation to:

- Address: Hot Water Heat Pumps Ltd, PO Box 21586, Henderson, Auckland 0650; or
- Email: [info@waterheating.co.nz](mailto:info@waterheating.co.nz)

### Warranty Terms

1. The TH-260D1 must be installed and certified by licensed and qualified installers according to instructions in the manual and all relevant local requirements.

2. The warranty only applies to TH-260D1 components supplied by Hot Water Heat Pumps Ltd. Other parts supplied by the installers are not covered by this warranty.
3. The TH-260D1 must only be used in normal domestic hot water applications.
4. The decision to repair or replace any components in the TH-260D1 will be entirely at the discretion of Hot Water Heat Pumps Ltd.
5. After any parts or heat pump replacement, the balance of the original warranty period will remain effective. The replaced parts or heat pump does not have a new warranty.
6. Travelling costs for repairs over one hour's drive from the service agents designated place of business shall be the owner's responsibility.
7. If the unit is installed in a position that is unsafe and difficult to access, the cost to relocate the TH-260D1 shall be the owner's responsibility.
8. The warranty does not cover aesthetic defects such as minor dents, scratches, and rust after the installation.
9. The warranty does not cover consequential losses arising from the failure of the TH-260D1.
10. This warranty service is only applicable to the original owner of the TH-260D1.

## **Warranty Exclusions**

This warranty does not apply to defects, failures and damages caused by:

1. Vandalism, accidents and acts of God.
2. Faulty installation that deviates from the manual's instructions and local requirements.
3. Hard or corrosive water.
4. Blockages due to foreign materials such as dust or debris.
5. Parts that are not specified by Hot Water Heat Pumps Ltd
6. Attempts to repair TH-260D1 by a person not authorised by Hot Water Heat Pumps Ltd.
7. Faulty plumbing that caused problems such as high water pressures and blockages.
8. Faulty electrical supply with bad wiring that caused problems such as voltage fluctuations and power surges.
9. External plumbing issues.
10. Poor maintenance such as blocked pressure relief valves.
11. Hash environmental conditions such as salty, sulphurous and corrosive air.
12. Any other issues not directly attributed to defects in TH-260D1.

The owner will be liable for any repair and replacement costs required by the TH-260D1 if the damages are caused by the events listed in this section.

# Warranty Registration Installation Declaration

Installer to complete for customer warranty record

Owner's Name

Product Serial Number

Installation Date

Installation Address

**Declaration:** I have installed and commissioned this Econergy Water Heater at the above address in compliance with the manufacturer's instruction manual.

COC Number

Installer Company Name/Trading Name

Installer Name

Installer Email Address

Signed

Date

Secondary Installer Company Name/Trading Name

Secondary Installer Name (Electrician or Plumber)

Secondary Installer Email Address

Signed

Date

0800 33 66 33 • [www.waterheating.co.nz](http://www.waterheating.co.nz) • [info@waterheating.co.nz](mailto:info@waterheating.co.nz)

3 Corban Avenue, Henderson, Auckland 0612 • PO Box 21586, Henderson, Auckland 0650



# HOT WATER HEAT PUMPS LTD

Advancing Water Heat Pump Technology

**SINCE 1980**