



## Titanium Series 8GP100CL-3vm Low Water Temperature Water Chiller

The Titanium Series 8GP100CL-3vm Water Chiller is part of our Performance Plus range of models. It ensures a constant set temperature every time. Suitable for chilling brine down to 1°C or a specified temperature.

Designed and engineered to perform all year round, even in New Zealand's harshest environments; the Titanium Series 8GP100CL-3vm unit is made of heavy gauge galvanised steel cabinetry with a polyester powder coat finish which provides superior corrosion resistance. The evaporator coils aluminium fins are epoxy coated giving extra protection in coastal areas where the air is salt-laden. The coil fins are on rifled copper tubes for even better heat transfer.

All 8GP series water chillers are fitted with a titanium tube heat exchanger, as titanium tubes provides superior resistance against corrosion. Due to its high energy efficiency, the Titanium Series 8GP100CL-3vm has an extremely low cost of operation.

### IDEAL APPLICATION

- Water chilling
- Aquaculture
- Hydroponics

### PERFORMANCE PLUS FEATURES

- Built in drain tray
- Water flow switch activated
- Titanium tube heat exchanger
- Ozone friendly refrigerants
- Epoxy coated corrosion resistant evaporator coils
- Built in refrigeration safety switches
- Electronic reverse cycle de-ice control
- Easy to operate electronic controller with digital display
- TX valve for more efficient low ambient operation
- Compressor has built in internal and external overload
- Optional WIFI or Modbus

Experience the best in water chiller technology



### PERFORMANCE PLUS BENEFITS

- Easy to install and operate
- Low operating costs and high efficiency
- Environmentally friendly
- Durable and long life expectancy
- Engineered and built in New Zealand
- Automatically maintains any set temperature in all weather



# Titanium Series 8GP100CL-3vm

## Technical Specifications

kW output (chilling) *1	68
kW output low temp (chilling) *2	46
kW input	20.0
Power Supply	3 Phase + N & E
Circuit Breaker – 3 Pole D Curve	80 amps
Nominal compressor run amps	15.2 x2
Fan full load amps	1.35 (x2)
Operating temperature range (fresh water) *3	4°C to 35°C
Minimum flow rate – litre/second	6
Water connections	Application Specific
Dimensions LxWxH – mm	2004 x 1254 x 2265
Weight – kg	660
Air volume @ high speed litre/second	5,200
Sound pressure level, high dB(A) *4	63/64

NB: Designs and specifications are subject to change without notice.

\*1 kW output values are nominal ratings based on 18°C water temperature, 35°C air at 60% RH.

\*2 kW output values are nominal ratings based on 7°C water temperature, 35°C air at 60% RH.

\*3 Low Temperature (CL) models can be engineered to chill to -5°C with sufficient Glycol solution to prevent freezing

\*4 Sound pressure measured at 3m in decibels re 20 µPa.



## Why buy from Hot Water Heat Pumps Ltd

**Back up and service:** You can be assured of unprecedented after-sales service. We provide free telephone and email support on all products, for the life of the product, even if you're outside of the warranty period. With periodic maintenance, your Hot Water Heat Pumps Ltd's product will provide you with a lifetime of efficient water heating and cooling technology.

**Warranty:** All of our industrial water chiller models carry a comprehensive two year parts and labour warranty, including the compressor, evaporator coil, heat exchanger and refrigeration systems. The titanium tube within the heat exchanger is covered against corrosion for 10 years.



**Safety first:** Our water chillers are fitted with protection systems to prevent damage in the event of a malfunction. Such as a flow switch to ensure the chillers cannot operate without water flow and other refrigeration safeties. If a problem is identified, the unit automatically shuts down before damage can occur. IP x4 rated.

**Energy efficient:** Government agency EECA (Energy Efficiency Conservation Authority) has listed heat pumps as one of the most energy efficient forms of heating in New Zealand.

## INSTALLATION INSTRUCTIONS

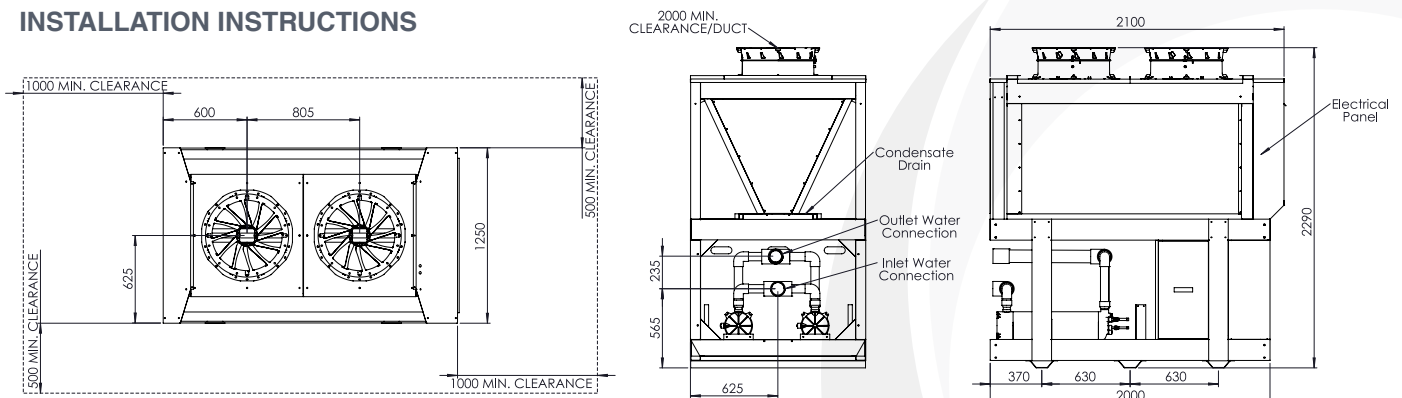

**Note:** 8G R32 Series heat pumps and chillers are not suitable for indoor/plant room installations without air quality monitoring and ventilation due to mild flammability.

3 Corban Avenue, Henderson, Auckland 0612  
 PO Box 21 586, Henderson, Auckland 0650  
 Phone 09 838 9444 Fax 09 838 6223  
 info@waterheating.co.nz

 **HOT WATER HEAT PUMPS LTD**  
 Advancing Water Heat Pump Technology SINCE 1980